

INSTALLATION GUIDE

Flare Connector Multi Angle

Model Type Code: FCMA

Visit www.smartlockfitting.com for video guide

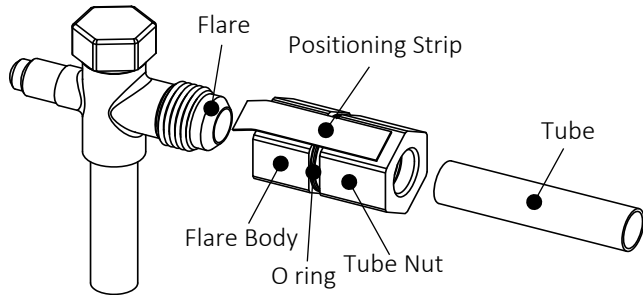

- 1** Allow the Tube to pass through the fitting. Butt the tube end against the flare end.

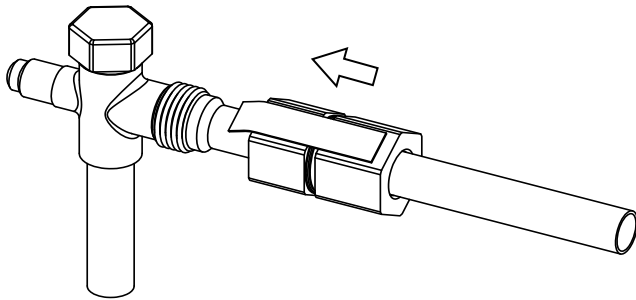

- 2** Slide the fitting to the flare threads and hand tighten the fitting until it stops.

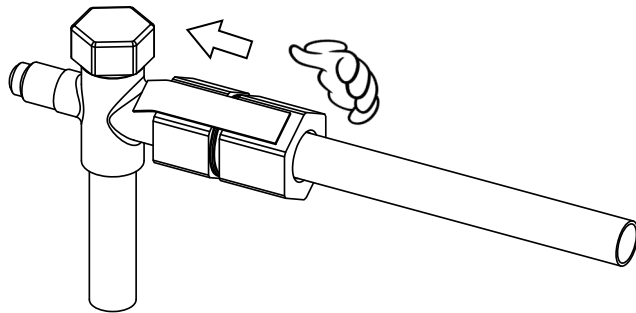

- 3** Remove the Positioning Strip.

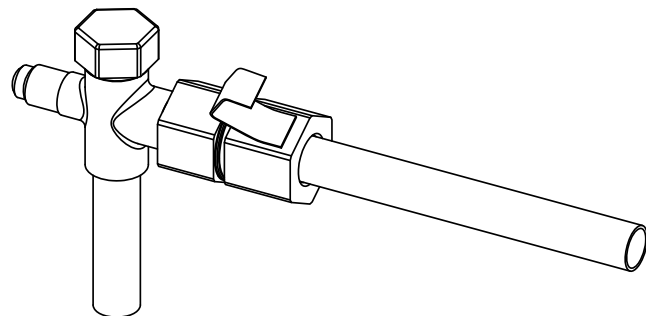

- 4** Hold the Flare Body and hand tighten the Nut until Tube locks.

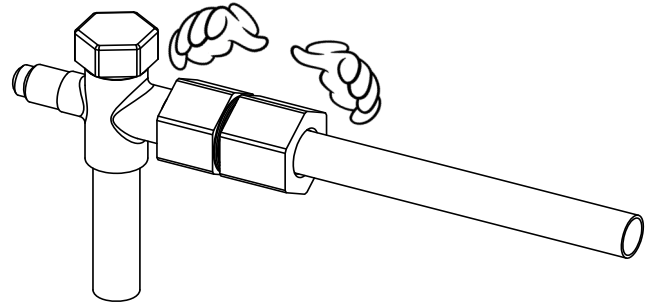

- 5** Wrench tighten the Tube Nut until Nut stops against the Body.

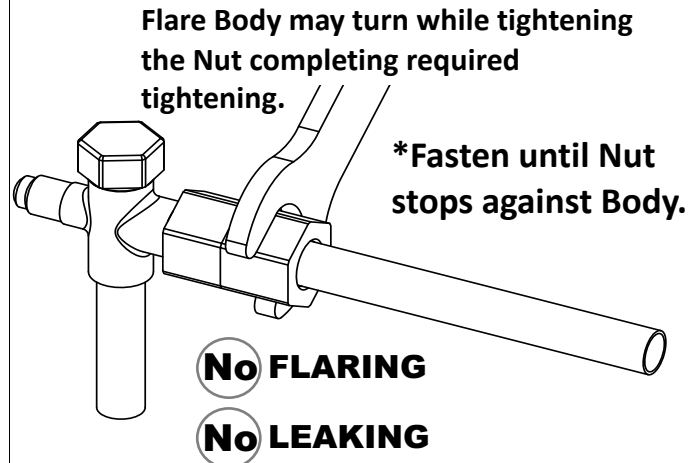

*Torque values available on website if desired

⚠ CAUTION

1. DO NOT REUSE.
2. DO NOT REMOVE POSITIONING STRIP PRIOR TO ASSEMBLY.
3. REMOVE BURRS FROM TUBING WITH CHAMFERING OR DEBURRING TOOL.
4. DO NOT USE DAMAGED TUBE AT 2 INCH FROM THE END OF THE TUBE.
5. DO NOT BEND TUBE AFTER CONNECTION IS MADE.
6. DO NOT USE OTHER THAN FOR INTENDED PURPOSE.



**HVAC/R
Fitting & Valve**

800 Port American Place #100 Grapevine, TX 76502

TEL: 980-333-4530 / FAX: 908-231-2094

sales@smartlockfitting.com

www.smartlockfitting.com